

## Hořák strojní SVM-105 Machine torch SVM-105

### plynem chlazený / gas cooling

Rozsah	20-105A
Zatěžovatel 60% / Duty	105A
Cykly 60%	
Plyn / Gas	Air/N <sub>2</sub>
Tlak / Gas pressure	řezání/cutting 5,0-5,5 bar drážkování/gouging 3,5-4,5 bar
Průtok plynu / Gas Flow	240 l/min
Dofuk / Post Flow Time	45s
Zapalování / Ignition	bez HF / without HF

CE  
IEC 60974-7

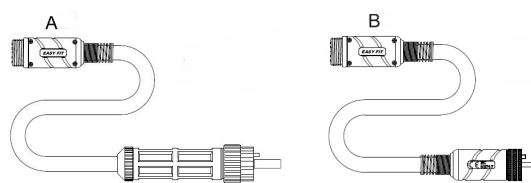

### Informace pro objednání Ordering Information

Poz./pos.	Kód/Code	Název / Description
1	7086	Hořák Plasma SVM-105 strojní Torch Plasma SVM-105 machine
A	7076	Kabel koax. 6,7 m SV-105/125 6 PIN Cable Package 6,7 m SVH/SVM-105/125 6 PIN
	7103	Kabel koax. 9,0 m SV-125 6 PIN Cable Package 9,0 m SV-125 6 PIN
B	7088	Kabel koax. prodlužovací 6,0 m SV-105/125 6 PIN Cable Package Extension 6,0 m SV-105/125 6 PIN

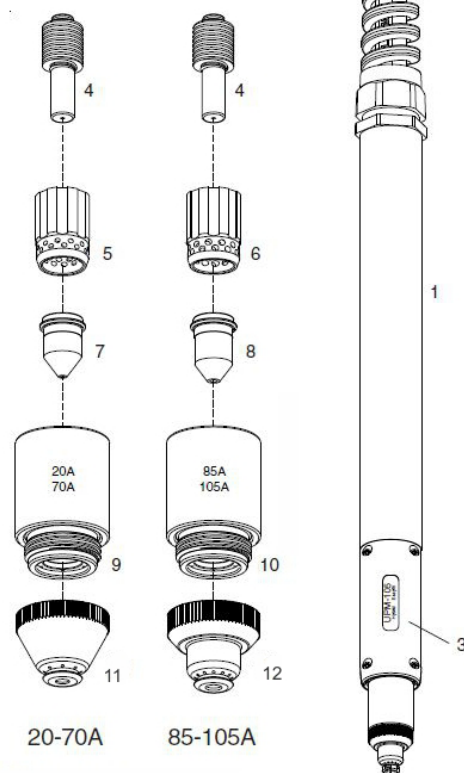

### Informace pro objednání / Ordering Information

Poz./pos.	Kód/Code	Název / Description	
	5790	O-kroužek TM-70, TM-105, TM-125, SVH/SVM-105(bal.2)	O-Ring TM-70, TM-105, TM-125, SVH/SVM-105(pkg.2)
1a	5791*	Trubka Poziční TM, SVM	Fibreglass Positioning Tube TM
4	5830*	Elektroda STM-70, TM-70, TM-105, SVH/SVM-105 (bal.10)	Electrode STM-70, TM-70, TM-105, SVH/SVM-105 (pkg.10)
5	5936	Rozdělovač plynu TM-70, TM-105, SVH-105 eco (bal.2)	Swirl Ring TM-70, TM-105, SVH-105 eco(pkg.2)
	5831	Rozdělovač plynu STM-70, TM-70 Max, TM-105, SVH-105 Life(bal.2)	Swirl Ring STM-70, TM-70, TM-105, SVH-105 Maximum Life(pkg.2)
6	6998*	Rozdělovač plynu 85-105A TM-105, SVH-105 eco (bal.2)	Swirl Ring 85-105A TM-105, SVH-105 eco pkg.2)
	6999	Rozdělovač plynu 85-105A TM-105, SVH-105 Life (bal.2)	Swirl Ring 85-105A TM-105, SVH-105 Life (pkg.2)
7	5832	Dýza 20-50A STM-70, TM-70, TM-105, SVH-105 (bal.10)	Tip 20-50A STM-70, TM-70, TM-105, SVH-105(pkg.10)
	5937	Dýza 70A TM-70, TM-105, SVH-105 (bal.10)	Tip 70A TM-70, TM-105, SVH-105(pkg.10)
8	7000	Dýza 85A TM-105, SVH/SVM-105 (bal.10)	Tip TM-105, SVH/SVM-105(pkg.10)
	7001*	Dýza 105A TM-105, SVH/SVM-105 (bal.10)	Tip 105A TM-105, SVH/SVM-105(pkg.10)
9	7070	Hubice 20-70A SVH-105	Shield Cup body 20-70A SVH-105
10	7071*	Hubice 80-105A SVH/SVM-105	Shield Cup body 80-105A SVH/SVM-105
11	5833	Hubice strojní 20-70A STM-70, TM-70, TM-105, SVM-105	Shield Cap Machine 20-70A STM-70, TM-70, TM-105, SVM-105
12	7003*	Hubice strojní 85-105A TM-105, SVM-105	Shield Cap Machine 85-105A TM-105, SVM-105

\* Standardní vybavení hořáku / Standard Layout